

**MODEL: GR-1450EX**

**SPECIFICATIONS**

<b>MAXIMUM CAPACITY</b>	145,000 kg at 2.5 m
<b>PERFORMANCE</b>	
Max. traveling speed (with counterweight)	15 km/h
Gradeability (tan $\theta$ ) (with 18.2 t counterweight)	52% (at stall), 30%* *Machine should be operated within limit of engine crankcase design (17: MITSUBISHI 6M60-TL).
<b>WEIGHT</b>	
Gross vehicle mass	90,805 kg
-1st axle	28,701 kg
-2nd axle	30,814 kg
-3rd axle	31,290 kg
<b>MIN. TURNING RADIUS</b>	14.9 m (2-wheel steering), 9.9 m (6-wheel steering) (at center of extreme outer tire)
<b>BOOM</b>	
Fully retracted length	13.1 m
Fully extended length	61.0 m
Extension speed	47.9 m in 450 s
Angle	1.5°-81.5°
Elevation speed	20° to 60° in 28 s
<b>JIB</b>	
Offset	Two staged slewing around boom extension;
Length	0°, 20°, 40° ** 10.3 m and 18.0 m
<b>MAIN WINCH</b>	
Single line pull	Variable speed type with grooved drum driven by hydraulic axial piston motor. 70.6 kN {7,200 kgf}
Single line speed	136 m/min. (at 4th layer)
Wire rope	19 mm (diameter)
<b>AUXILIARY WINCH</b>	
Single line pull	Variable speed type with grooved drum driven by hydraulic axial piston motor. 70.6 kN {7,200 kgf}
Single line speed	136 m/min. (at 4th layer)
Wire rope	19 mm x 320 m (Diameter x length)
<b>SLEWING</b>	
Slewing speed	1.3 min <sup>-1</sup> {rpm}
Tail slewing radius	4,600 mm
<b>HYDRAULIC SYSTEM</b>	
	Pumps... 2 variable piston pumps for crane functions. Tandem gear pump for steering, slewing and other equipment. Control valves... Multiple valves actuated by pilot pressure with integral pressure relief valves. Circuit... Equipped with air cooled type oil cooler. Oil pressure appears on AML display for main circuit. Hydraulic oil tank capacity... approx. 763 liters Filters... Return line filter

<b>TADANO Automatic Moment Limiter (Model: AML-C)</b>	Following information is displayed: • Load as percentage • Number of parts of line • Boom angle • Boom length • Load radius • Outriggers position • On-rubber indicator • Actual hook load • Permissible load • Boom position indicator • Potential lifting height • Slewing angle • Main hydraulic oil pressure • Jib length and jib offset angle (only when jib in operation)
<b>OUTRIGGERS</b>	Hydraulically operated H-type outriggers. Each outrigger controlled simultaneously or independently from cab. Equipped with sight level gauge. Floats can be stowed on vertical cylinders or removed to improve approach and departure angles. All cylinders fitted with pilot check valves. Crane operation with different extended length of each outrigger. Equipped with extension width detector for each outrigger. Outrigger unit is self-removable for ease of transportation. Extension width Max. ... 8,200 mm, Mid. ... 7,300 mm & 5,500 mm Min. ... 2,990 mm, Float size (diameter) ... 570 mm
<b>CARRIER</b>	Rear engine, left-hand steering, driving axle 2-way selected type by manual switch. 6 x 2 1st drive, 6 x 4 1st and 3rd drive
<b>ENGINE</b>	Model ... MITSUBISHI 6M60-TL Type ... 4-cycle, turbo charged and after cooled, 6 cylinder in-line, direct injection, water cooled diesel engine. Piston displacement... 7,540 cm <sup>3</sup> Max. output... 200 kW at 2,600 min <sup>-1</sup> {rpm} Max. torque... 785 N·m at 1,400 min <sup>-1</sup> {rpm}
<b>TRANSMISSION</b>	Electronically controlled full automatic transmission.
<b>STEERING</b>	Hydraulic power steering. 4 steering modes available: 2-wheel front, 4-wheel rear 6-wheel coordinated, 6-wheel crab
<b>SUSPENSION</b>	1st... Rigid mounted to frame. 2nd, 3rd... "Hydro-Pneumatic suspension cylinders" with leveling adjustment and oscillation.
<b>TIRES</b>	26.5R25☆☆☆, Air pressure: 650 kPa
<b>FUEL TANK CAPACITY</b>	300 liters

**WORKING RANGE**

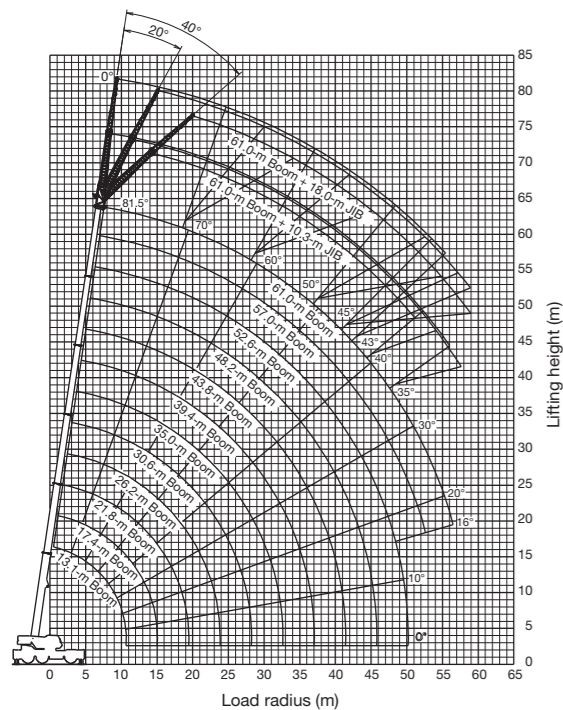

**DIMENSIONS**

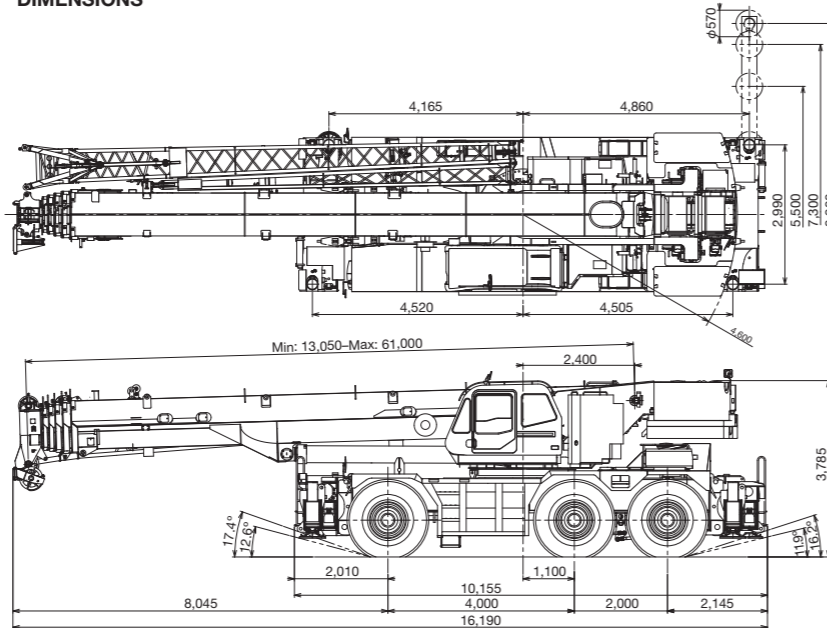

\*Some specifications are subject to change



Lifting your dreams

**ROUGH TERRAIN CRANE**

# GR-1450EX

**145 METRIC TON CAPACITY**

**ROUGH TERRAIN CRANE**



*The GR-1450EX:  
High Quality We Are Proud Of*



**TADANO LTD.** (International Sales Division)  
4-12, Kamezawa 2-chome, Sumida-ku Tokyo 130-0014, Japan  
Phone: +81-3-3621-7750 Fax: +81-3-3621-7785  
<http://www.tadano.com/> E-mail: [info@tadano.com](mailto:info@tadano.com)





Crane capacity: 145,000 kg at 2.5 m  
 6-section long boom: 13.1 m - 61.0 m  
 2-staged bi-fold jib: 10.3 / 18.0 m

# ROUGH TERRAIN CRANE GR-1450EX

## The Debut of a New Generation of Crane!

Tadano has launched a new rough terrain crane that boasts the world's largest class hoisting capacity. Utilizing a compact three-axle carrier as a base, our new crane combines the capability of an all terrain crane with the ease of operation and secure functionality of a rough terrain crane. In addition, environmental consciousness, enhanced safety, and equipment designed to maximize work efficiency are all standard features of the new crane. Tadano's new, next-generation crane has just made its world debut.

## Plenty of new functions incorporated!

### HELLO-NET system

It is a crane management system available to be used on the Internet that is capable of taking a grip on crane operating conditions, a machine location and so forth in a timely manner which serve to widen the service area differs according to individual countries.

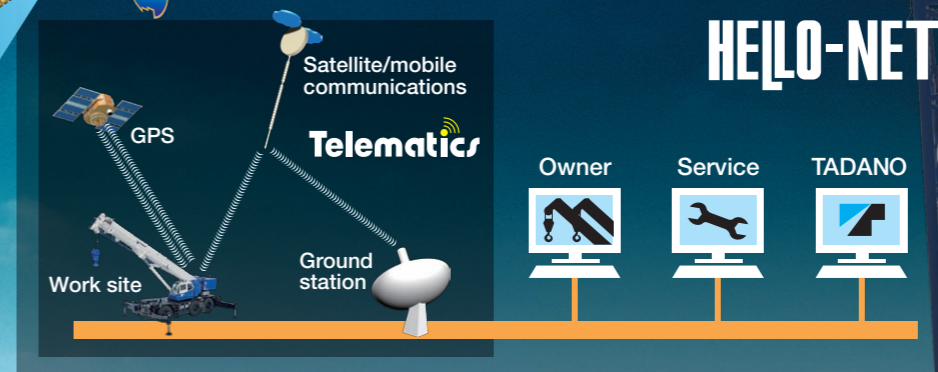

Note: There are some countries where the system is not in use yet. For detail, please contact your distributor or our sales staff in charge.

### Eco mode system

The system controls the maximum engine speed during crane operation. In addition, due to curbing an unnecessary rise in the engine speed that occurs when accelerated to excess, the system enables CO<sub>2</sub> emissions and fuel consumption to decrease by max. 13 % with the Eco mode 1 employed, and max. 21 % when the Eco mode 2 is applied. In addition, it realizes a low level of noise.



### Positive control system

The system effectively controls the quantity of hydraulic pump discharge at the time of crane operation in response to the amount of movement applied by the operating lever. Additionally, it keeps the quantity of hydraulic pump discharge to a minimum, reducing CO<sub>2</sub> emissions and fuel consumption by up to 20 %.



### Fuel monitoring system

The system constantly monitors and displays on the AML screen information on fuel consuming conditions. Checking the indicator enables you to prevent wasteful acceleration and wasteful standby.

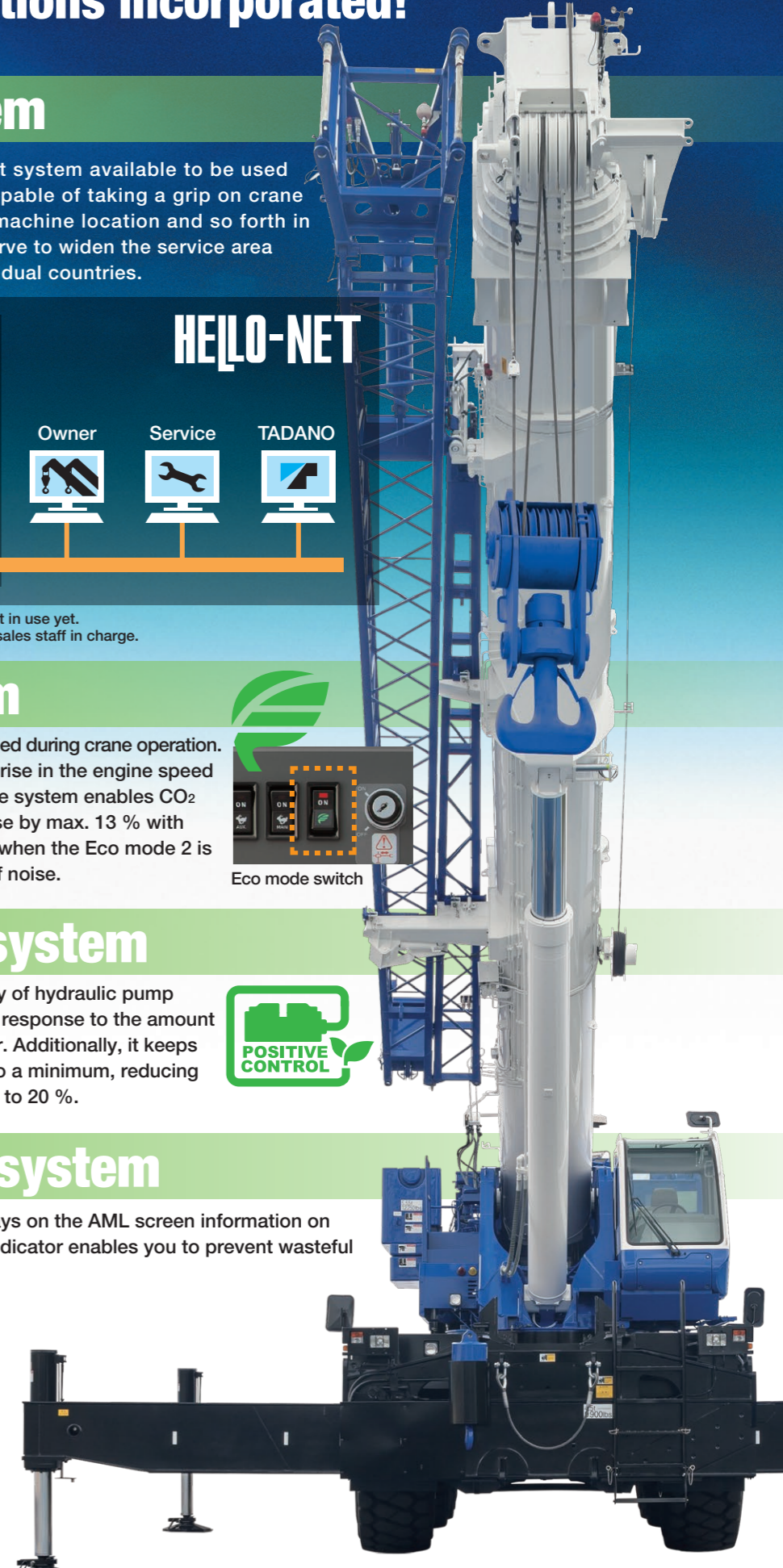
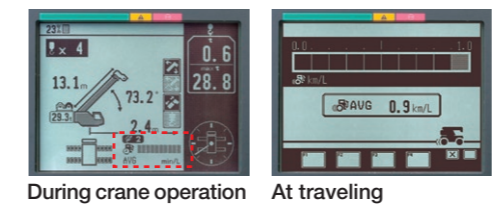

# Crane

The rounded boom is made of high tensile steel, which allows for decreased boom weight as well as increased boom strength. In addition, the high-performance AML-C ensures safe operation.

## Single telescopic cylinder

For extension and retraction of sections, 6 section box type construction consist of 1 base section and 5 telescopic sections are extended by a single telescoping cylinder. All sections are fully extended/retracted automatically and locked in the selected working position.

**New Design**

## Ultimate boom for rough terrain crane

The rounded boom constructed of high tensile steel contributes to decreased boom weight and increased boom strength.

## Outline of telescoping mode

The boom telescopic of this crane is performed with one telescoping cylinder. Each telescopic section is extended and fixed with pins in sequence from the top with several telescoping modes based on the designated job plan.

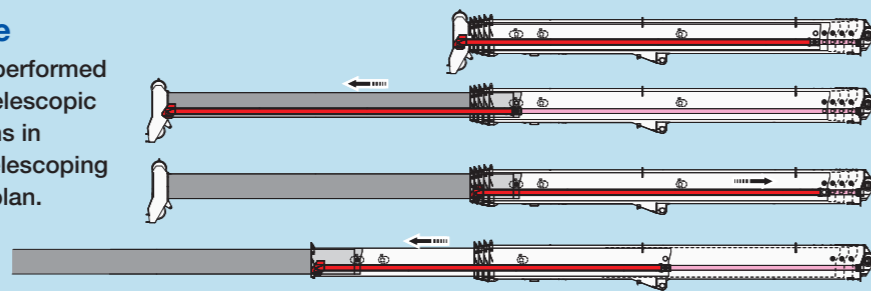

## Display telescoping status

A single cylinder and each section of boom actual condition are displayed on the AML by Telescoping monitor switch.



Telescoping status indicator

## AML displays load moment indicator

No.	m	1	2	3	4	5
1	0	0	0	0	0	0
2	17.4	0	0	0	0	45
3	21.8	0	0	0	0	90
4	26.2	0	0	0	45	90
5	30.6	0	0	0	90	90
6	35.0	0	0	40	90	90
7	39.4	0	0	90	90	90
8	43.8	0	40	90	90	90
9	48.2	0	90	90	90	90

Telescoping menu screen

Telescoping status screen

## Two winches with cable follower

Both the main winch and the auxiliary winch with powerful line pull operate at high speeds, thus serving to enhance work efficiency.

\*Maximum permissible line pull may be affected by wire rope strength.

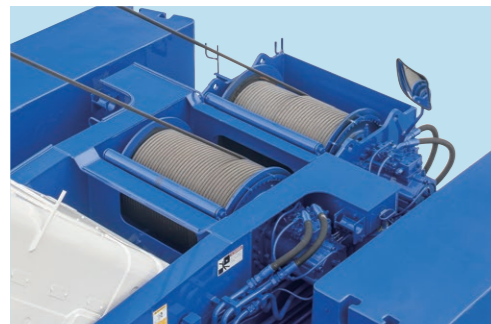

## New crane structure

When developing the crane structure, we attached importance to the shape of it that is most suited for crane operation, and realized it by making full use of a \*FEM analysis. As for the swing frame, we adopted a new structure of TADANO's original conception to secure its high rigidity as well as keeping the configuration in a compact style along with the overall height being retained at a desired level.

\*FEM: Finite Element Method

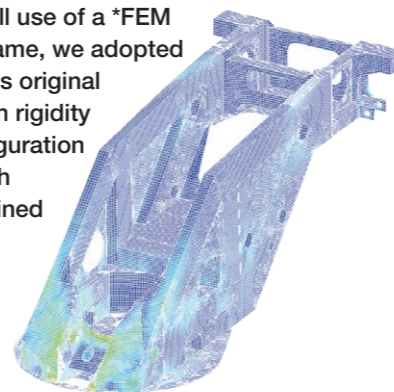

**By-fold jib**  
A two-stage, bi-fold lattice-type jib can be offset at 0°, 20°, and 40° to enable the operator to carry out jobs that require extra reaching ability.

10.3/18.0 m

**Longest boom in its class**  
13.1-61.0 m



## Assist cylinder for jib

When mounting and storing the jib, assistant hydraulic cylinders ensure effective operation, thus increasing the work efficiency of jib mounting and storage.



## Outline of jib installation

Base jib + Top jib

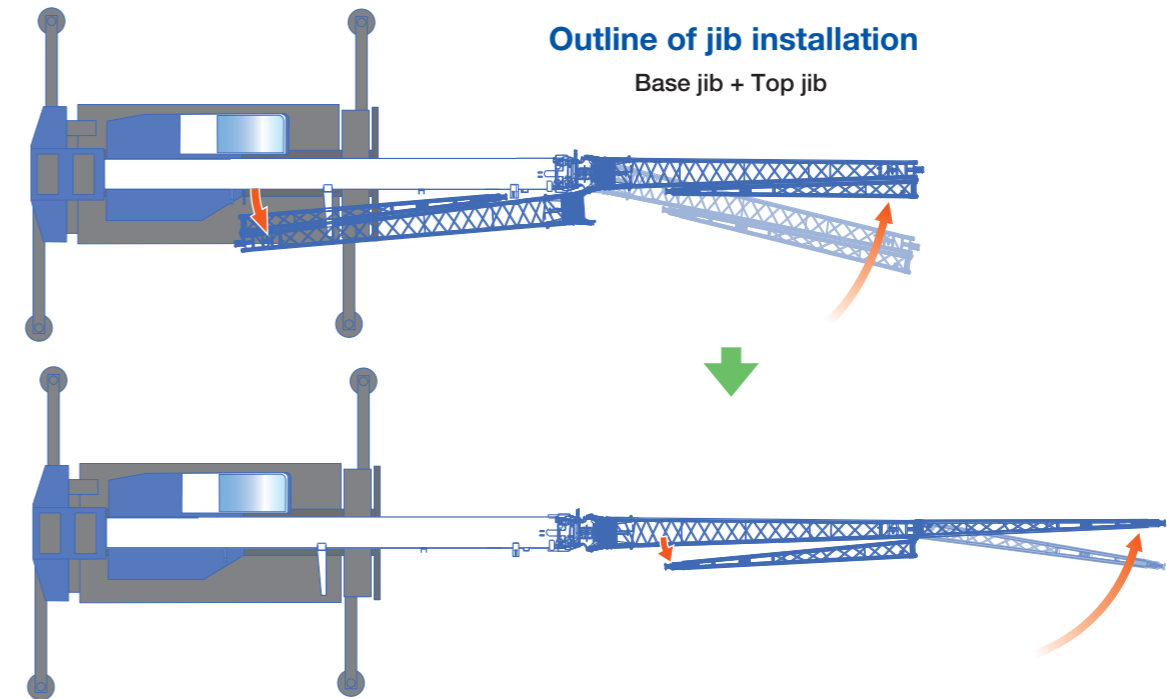

## Tiltable cab

You can operate the crane comfortably by tilting the cab during high hoisting operations such as lifting the jib.

The cab tilting angle is between 0° and 15°.

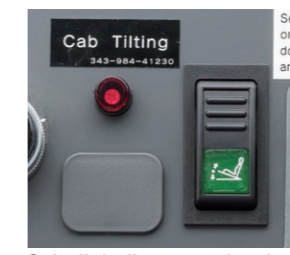

Cab tilt indicator and switch

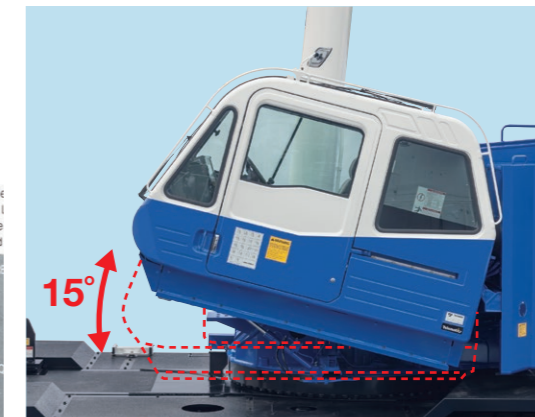

81.5°



## Automatic moment limiter [AML-C]



Tadano's new AML-C is easy to use. It allows the operator to simultaneously monitor: boom angle, boom length, elevating cylinder operating pressure, the extended length of the outriggers, swing position, rated lifting capacity and present hook weight. All of this enables the AML-C to move easily through lifting capacity changes without changing configurations and codes to make a lift.

The AML-C provides both audio and visual warnings when a condition exists that will overload the crane and automatically employs our soft stop function to avoid shock loads.

The AML-C with "OPERATOR" pre-set working range limits and automatic soft stop functions will assist the operator to deliver safe smooth operations for years to come.



AML lamp

## Control of asymmetric extension width of outriggers

When operating the crane with the asymmetric outriggers extended, the AML-C automatically detects the extension width of outriggers at the front and rear, and to the left and right of the crane to offer maximum work value through each area.

When slewing the boom from the longer outrigger area to the shorter outrigger area, the AML-C automatically detects the motion and displays the maximum capacity depending on each extension width of the outriggers, and brings the motion to a slow stop before it reaches the limits of the allowed capacity.

Therefore, even if the operator operates the crane without being aware of a change in the capacity, the AML-C monitors it continuously to ensure safe operation.

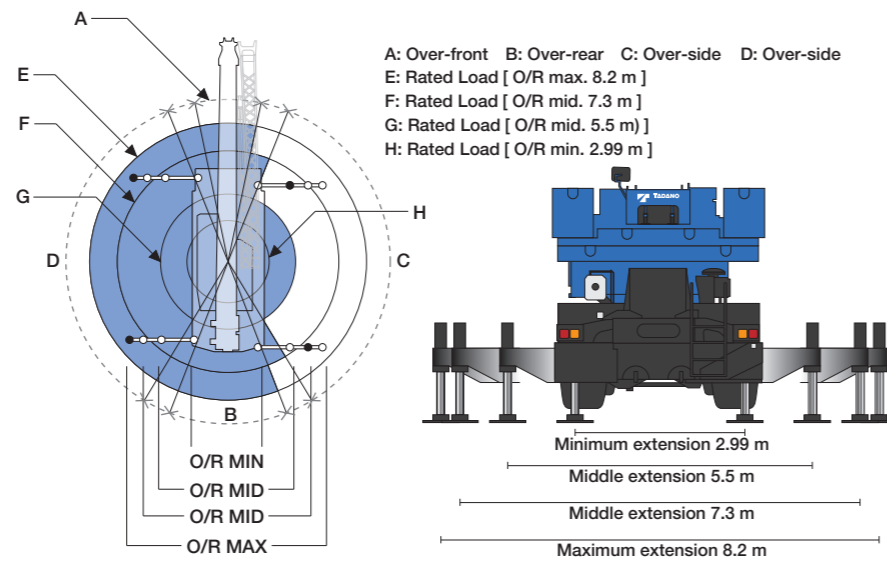
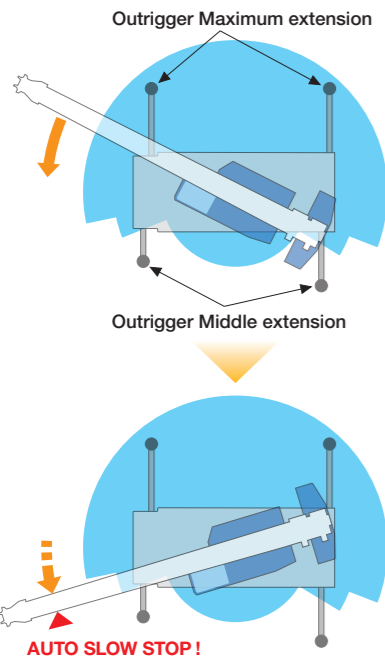
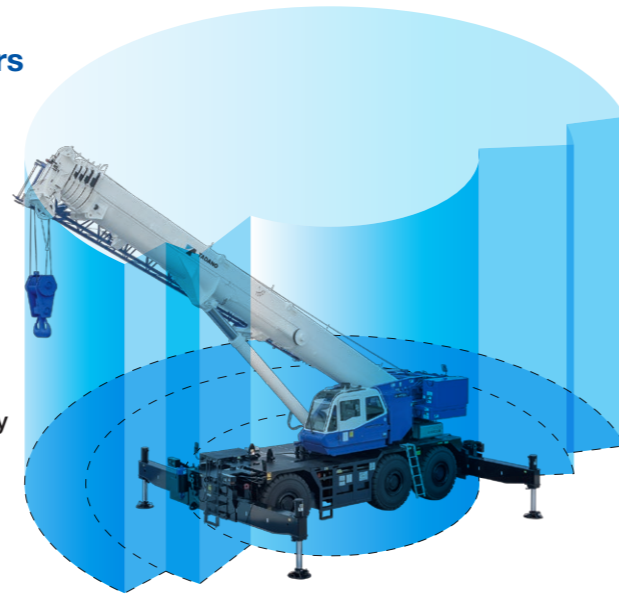

## Operator comfort

The crane cabin provides improved livability and offers the operator a more comfortable working environment.

The crane operating levers are of finger control type and surely and steadily respond to the operator.



Front steps



Rear steps



Left side steps



Air conditioner  
 Hot-water heater and air conditioning.

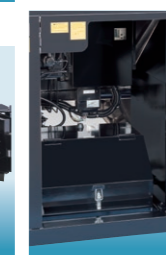

Tool box



Aviation obstruction light (option)  
 and anemometer (option)

**New Design**

**Compact carrier for rough terrain crane**

The GR-1450EX has a 3-axle, compact width/height carrier which offers improved maneuverability and the ability to reduce space for transportation.



- Overall length: approx. 16,190 mm
- Overall width: approx. 3,315 mm  
approx. 3,500 mm (+ Extra weights)
- Overall height: approx. 3,785 mm
- Min. turning radius (at center of extreme outer tire)
  - 2-wheel steering: 14.9 m
  - 6-wheel steering: 9.9 m
- Max. traveling speed (with counterweight): 15 km/h
- Gradeability (tan  $\theta$ ) (with 18.2t counterweight): computed 52 % (at stall) \*30 %
- \* Machine should be operated within the limit of engine crankcase design (17': MITSUBISHI 6M60-TL).

**Smooth transmission**

- Electronically controlled, fully automatic transmission.
- Torque converter driving full power shift with driving axle selector.
- 5 forward and 2 reverse speeds, constant mesh.
- 2 speeds - High range - 2 wheel drive ; 4 wheel drive
- 3 speeds - Low range - 4 wheel drive

**New carrier frame**

We developed and built the carrier frame so that lightness in weight could be compatible with its high rigidity at an advanced level of performance. As a result, the rigidity was enhanced to enable highly stabilized maneuverability.

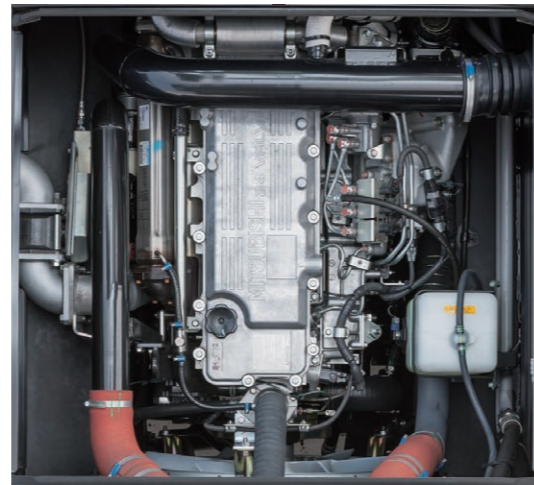
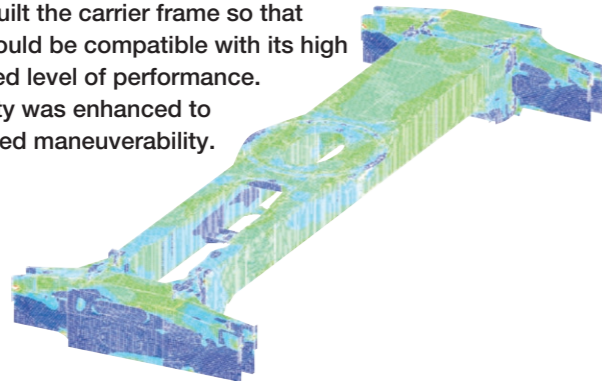

**High performance engine**

MITSUBISHI 6M60-TL  
4 cycle, turbo charged and after cooled, 6 cylinder in line, direct injection, water cooled diesel engine.

Max. output: 200 kW at 2,600 min<sup>-1</sup> {rpm}  
Max. torque: 785 N-m at 1,400 min<sup>-1</sup> {rpm}



**Axle**

- 1st: Full floating type, steering and driving axle with planetary reduction and open differential.
- 2nd: Steering and not driving axle.
- 3rd: Full floating type, steering and driving axle with planetary reduction and open differential.

**Brake systems**

- Service: Air over hydraulic disc brakes on all 6 wheels.
- Parking/Emergency: Spring applied-air released brake acting on input shaft of 1st and 3rd axle.
- Auxiliary: Electro-pneumatic operated exhaust brake.



**4 Steering mode**

Hydraulic power steering controlled by steering wheel.

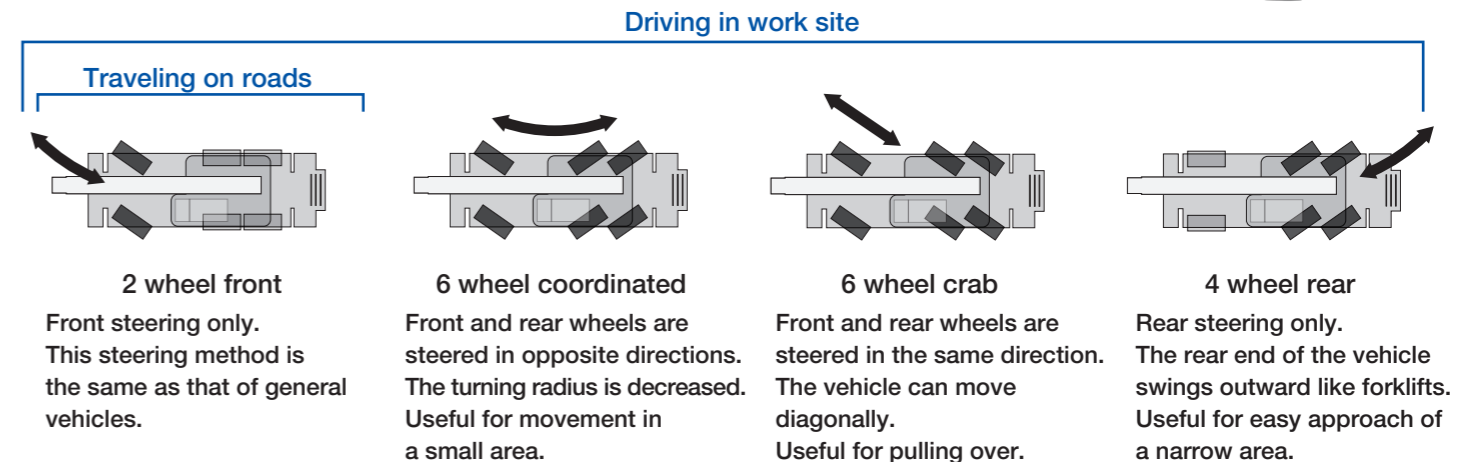

# Mounting and dismounting systems

The GR-1450EX has several "mounting and dismounting systems" for traveling and transportation. Only the boom mounting/dismounting system is optional.

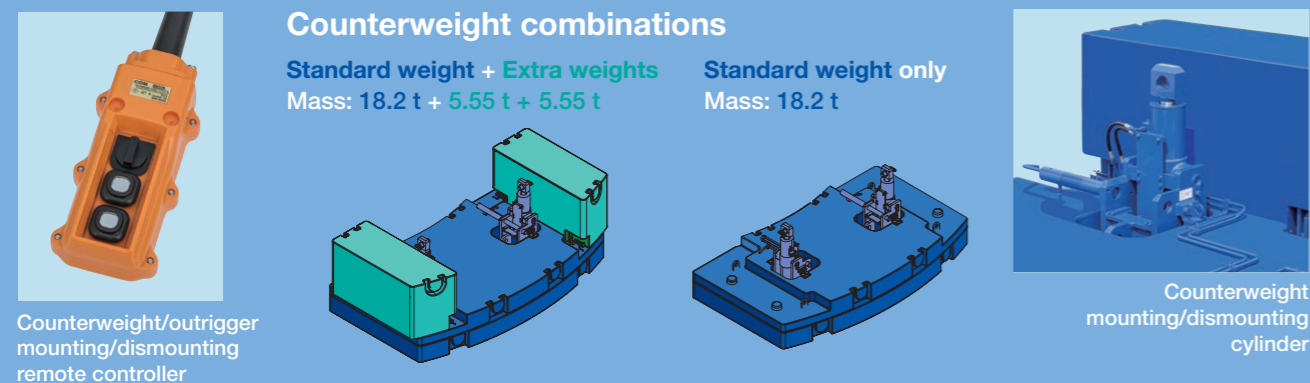
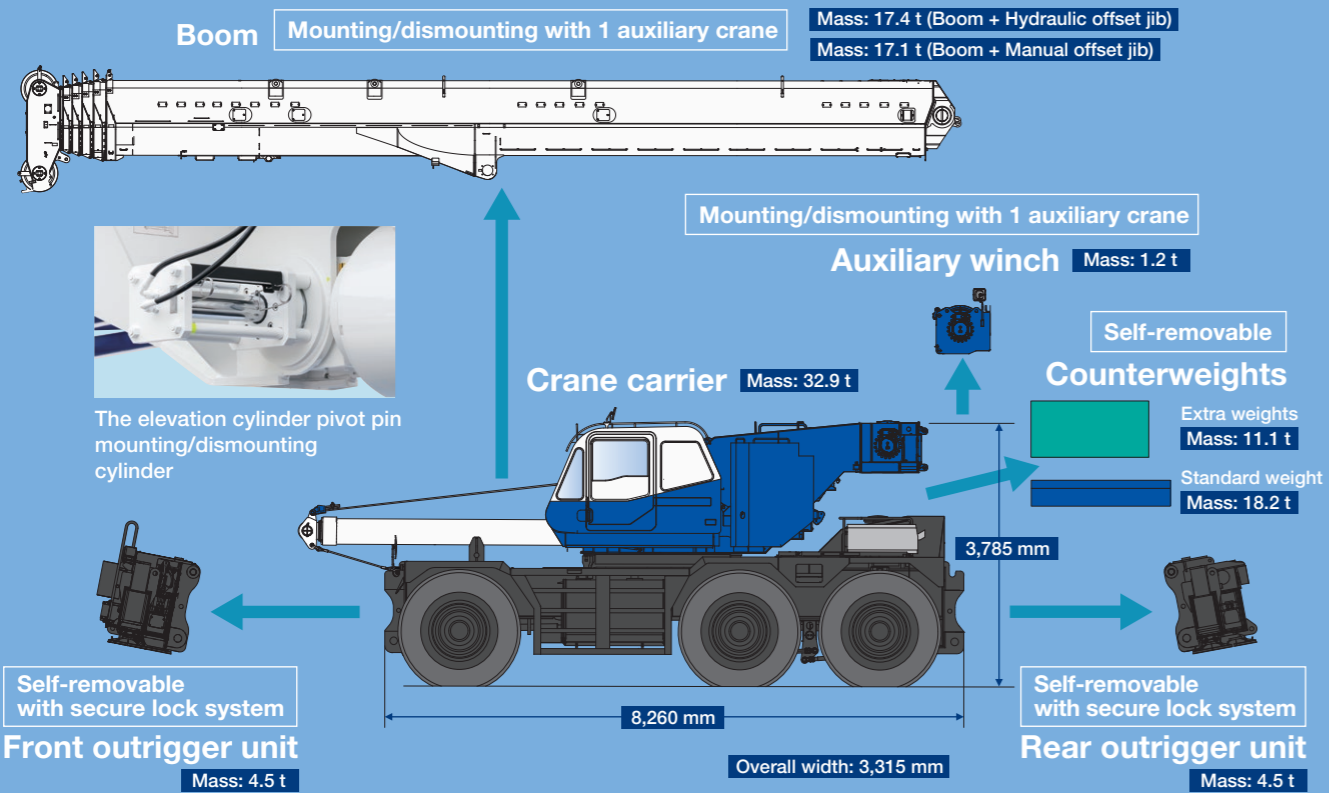

## Self-removable counterweight

Counterweight along with an auxiliary hoist is hydraulically mounting/dismounting; in addition, dismantled counterweight can be lifted and moved for transport without a helper crane, as well as being re-mounted at a work site for operation.



Front

Left



Rear

Right