

TADANO CARGO CRANE

MODEL : **TM-ZE554HS**

CRANE SPECIFICATIONS

<u>CRANE CAPACITY</u>	5,000 kg at 2.5 m (5-part line)
<u>BOOM</u>	Four-sectioned, fully powered partly synchronized telescoping boom of heptagonal box construction Retracted length----- 3.55 m Extended length -----10.8 m Extending speed ----- 7.25 m / 21 s Elevation ----- Elevated by a double-acting hydraulic cylinder Elevating speed ----- 1° to 78° / 12 s Boom point ----- 3 sheaves
<u>WINCH</u>	Hydraulic motor driven Spur gear speed reduction, provided with mechanical brake Single line pull ----- 9.90 kN {1,010 kgf} Single line speed ----- 66 m/min (at 4th layer) Wire rope Diameter x length --- 8 mm x 82 m Breaking strength --- 50.1 kN {5.1 tf} Construction ----- 7 x 7 + 6 x WS(26) Hook block ----- 2 sheaves
<u>HOOK STOWING DEVICE</u>	Mechanically stowed beneath boom top portion

Specifications are subject to change without notice

SLEWING

Hydraulic motor driven Worm gear speed reduction
 Continuous 360° full circle slewing on ball bearing slew ring
 Automatic slewing lock
 Slewing speed ----- 2.5 min⁻¹ {rpm}

OUTRIGGERS

Manually extended sliders and hydraulically extended jacks
 Integral with crane frame Power up and down
 Extended width ----- Min. 2,200 mm
 Mid. 3,000 mm
 Max.3,800 mm

HYDRAULICS

Hydraulic pump ----- Single gear pump
 Hydraulic motors ----- Axial piston type for winch
 Axial piston type for slewing
 Control valves ----- Multiple control valves with integral
 safety valve
 Oil tank capacity ----- approx. 48 L

SAFETY DEVICES

AML(Automatic Moment Limiter)
 Load indication
 Load moment ratio to rated load indication
 Warning alarm
 Over load limiter
 WHL(Working Height Limiter)
 Load indicator
 Over-unwinding prevention
 Terminal for emergency stop switch
 Over-winding alarm
 Anti-two-block device
 Hook safety latch
 Hydraulic safety valves, check valves and holding valves
 Level gauge

CRANE MASS

Approx. 1,860 kg (includes standardized mounting parts)

NOTE : Operating speeds of the crane are guaranteed under the condition that the pump delivery is 60 L/min.

RATED LIFTING CAPACITIES IN KILOGRAMS

Crane Strength Rated Capacities

Load Radius	3.55 m Boom	Load Radius	5.99 m Boom	Load Radius	8.39 m Boom	Load Radius	10.8 m Boom
2.5 m and below	5,000	2.5 m and below	4,000	2.5 m and below	3,080	3.5 m and below	2,080
2.9 m	4,000	2.9 m	4,000	3.0 m	3,080	4.5 m	2,080
3.33m	3,500	3.7 m	3,080	3.7 m	3,080	5.0 m	1,980
		4.0 m	2,880	4.0 m	2,880	6.0 m	1,730
		4.5 m	2,530	4.5 m	2,530	7.0 m	1,480
		5.0 m	2,280	5.0 m	2,280	8.0m	1,330
		5.77 m	1,980	5.5 m	2,030	9.0m	1,150
				6.0 m	1,880	10.0 m	1,000
				6.5 m	1,730	10.58m	950
				7.0 m	1,580		
				7.5 m	1,430		
				8.17m	1,330		

- NOTES : 1. Capacities in these tables include slings and similarly used load lifting devices, and they must be added to the mass of the load. They don't, however, include the mass of hook block (45kg).
2. The above numerical values of total rated loads are based on crane strength only. The total rated loads based on stability may lower than those in the above table depending on the loading conditions and the types of the chassis.

Empty Chassis Rated Capacities

Table A

Load Radius	3.55 m Boom		Load Radius	5.99 m Boom		Load Radius	8.39 m Boom		Load Radius	10.8 m Boom	
	Extension width of outriggers			Extension width of outriggers			Extension width of outriggers			Extension width of outriggers	
	Maximum	Minimum		Maximum	Minimum		Maximum	Minimum		Maximum	Minimum
2.5 m and below	5,000	2,430	2.6 m and below	4,000	2,430	2.6m and below	3,080	2,430	3.5 m and below	2,080	1,430
2.8 m	4,000	2,080	2.8 m	4,000	2,080	3.0 m	3,080	1,830	4.0 m	2,080	1,130
3.33m	3,200	1,580	3.6 m	2,880	1,380	3.6 m	2,880	1,380	4.5 m	1,930	880
			4.0 m	2,380	1,130	4.0 m	2,380	1,130	5.0 m	1,580	730
			4.5 m	1,930	880	4.5 m	1,930	880	6.0 m	1,130	530
			5.0 m	1,630	780	5.0 m	1,630	780	7.0 m	950	400
			5.77m	1,280	630	5.5 m	1,380	630	8.0 m	750	330
						6.0 m	1,130	530	9.0 m	630	280
						6.5 m	1,080	500	10.0 m	530	230
						7.0 m	950	430	10.58m	500	200
						7.5 m	850	380			
						8.17m	730	330			

Table B

Load Radius	3.55 m Boom		Load Radius	5.99 m Boom		Load Radius	8.39 m Boom		Load Radius	10.8 m Boom	
	Extension width of outriggers			Extension width of outriggers			Extension width of outriggers			Extension width of outriggers	
	Maximum	Minimum		Maximum	Minimum		Maximum	Minimum		Maximum	Minimum
2.5 m and below	5,000	2,680	2.3 m and below	4,000	3,080	2.3m and below	3,080	3,080	3.5 m and below	2,080	1,680
2.9 m	4,000	2,330	2.9 m	4,000	2,330	3.0 m	3,080	2,230	4.0 m	2,080	1,380
3.33m	3,500	1,880	3.7 m	3,080	1,530	3.7 m	3,080	1,530	4.5 m	2,080	1,130
			4.0 m	2,880	1,380	4.0 m	2,880	1,380	5.0 m	1,930	880
			4.5 m	2,380	1,130	4.5 m	2,380	1,130	6.0 m	1,430	680
			5.0 m	1,980	930	5.0 m	1,980	930	7.0 m	1,130	530
			5.77m	1,580	730	5.5 m	1,680	780	8.0 m	900	430
						6.0 m	1,430	680	9.0 m	830	380
						6.5 m	1,330	630	10.0 m	680	300
						7.0 m	1,180	580	10.58m	630	280
						7.5 m	1,030	480			
						8.17m	930	430			

Table C

Load Radius	3.55 m Boom		Load Radius	5.99 m Boom		Load Radius	8.39 m Boom		Load Radius	10.8 m Boom	
	Extension width of outriggers			Extension width of outriggers			Extension width of outriggers			Extension width of outriggers	
	Maximum	Minimum		Maximum	Minimum		Maximum	Minimum		Maximum	Minimum
2.5 m and below	5,000	3,080	2.6 m and below	4,000	3,080	2.5m and below	3,080	3,080	3.5 m and below	2,080	1,880
2.9 m	4,000	2,630	2.9 m	4,000	2,630	3.0 m	3,080	2,580	4.5 m	2,080	1,280
3.33m	3,500	2,180	3.7 m	3,080	1,820	3.7 m	3,080	1,820	5.0 m	1,980	1,030
			4.0 m	2,880	1,580	4.0 m	2,880	1,580	6.0 m	1,730	730
			4.5 m	2,530	1,330	4.5 m	2,530	1,330	7.0 m	1,430	680
			5.0 m	2,280	1,080	5.0 m	2,280	1,080	8.0 m	1,150	500
			5.77m	1,980	880	5.5 m	1,980	880	9.0 m	980	450
						6.0 m	1,780	780	10.0 m	850	380
						6.5 m	1,600	730	10.58m	780	330
						7.0 m	1,430	680			
						7.5 m	1,300	600			
						8.17m	1,130	500			

Table D

Load Radius	3.55 m Boom		Load Radius	5.99 m Boom		Load Radius	8.39 m Boom		Load Radius	10.8 m Boom	
	Extension width of outriggers			Extension width of outriggers			Extension width of outriggers			Extension width of outriggers	
	Maximum	Minimum		Maximum	Minimum		Maximum	Minimum		Maximum	Minimum
2.5 m and below	5,000	3,330	2.5 m and below	4,000	3,330	2.5m and below	3,080	3,080	3.5 m and below	2,080	1,880
2.9 m	4,000	2,630	2.9 m	4,000	2,630	3.0 m	3,080	2,580	4.5 m	2,080	1,280
3.33m	3,500	2,180	3.7 m	3,080	1,820	3.7 m	3,080	1,820	5.0 m	1,980	1,030
			4.0 m	2,880	1,580	4.0 m	2,880	1,580	6.0 m	1,730	730
			4.5 m	2,530	1,330	4.5 m	2,530	1,330	7.0 m	1,480	680
			5.0 m	2,280	1,080	5.0 m	2,280	1,080	8.0 m	1,330	500
			5.77m	1,980	880	5.5 m	2,030	880	9.0 m	1,150	450
						6.0 m	1,880	780	10.0m	1,000	380
						6.5 m	1,730	730	10.58m	950	330
						7.0 m	1,580	680			
						7.5 m	1,430	600			
						8.17m	1,330	500			

- NOTES: 1. Empty Chassis Rated Capacities in these tables depend on condition that crane is set level on firm level ground.
2. Capacities in these tables include slings and similarly used load Lifting devices, and they must be added to the mass of the load. They don't, however, include the mass of hook block (45kg).
3. For boom lengths not shown, use the rated lifting capacity of next longer boom.
4. When outriggers are extended to middle extension width, use the rated lifting capacities for outriggers are extended to minimum extension width.
5. 8.39m boom means \sphericalangle mark on 3rd boom section side plate is half seen.
6. Empty Chassis Rated Capacities table A, B, C and D depend on the types of chassis.
7. Empty Chassis Rated Capacities are shown for over - side areas and over-rear area. These capacities for over - front area may lowered depending on the types of chassis

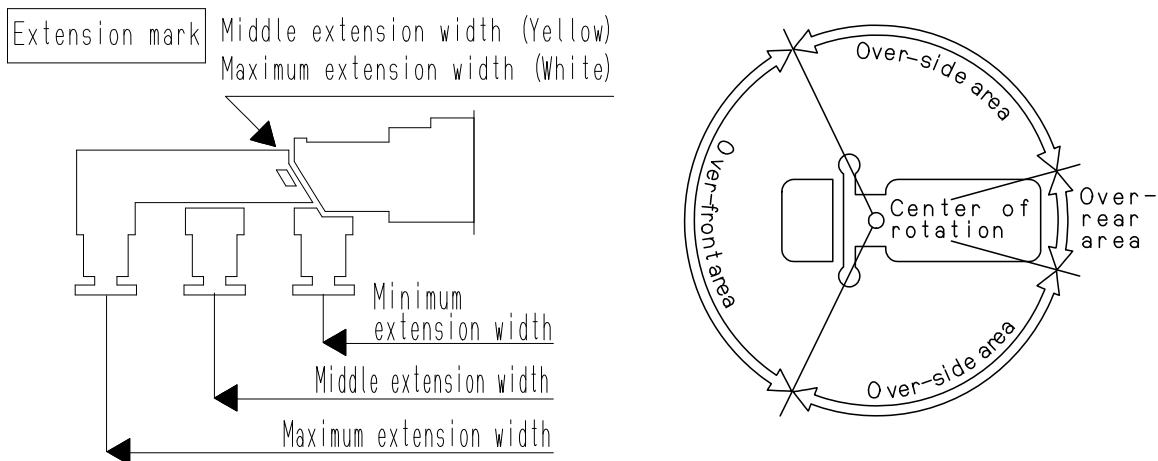

WORKING RANGE

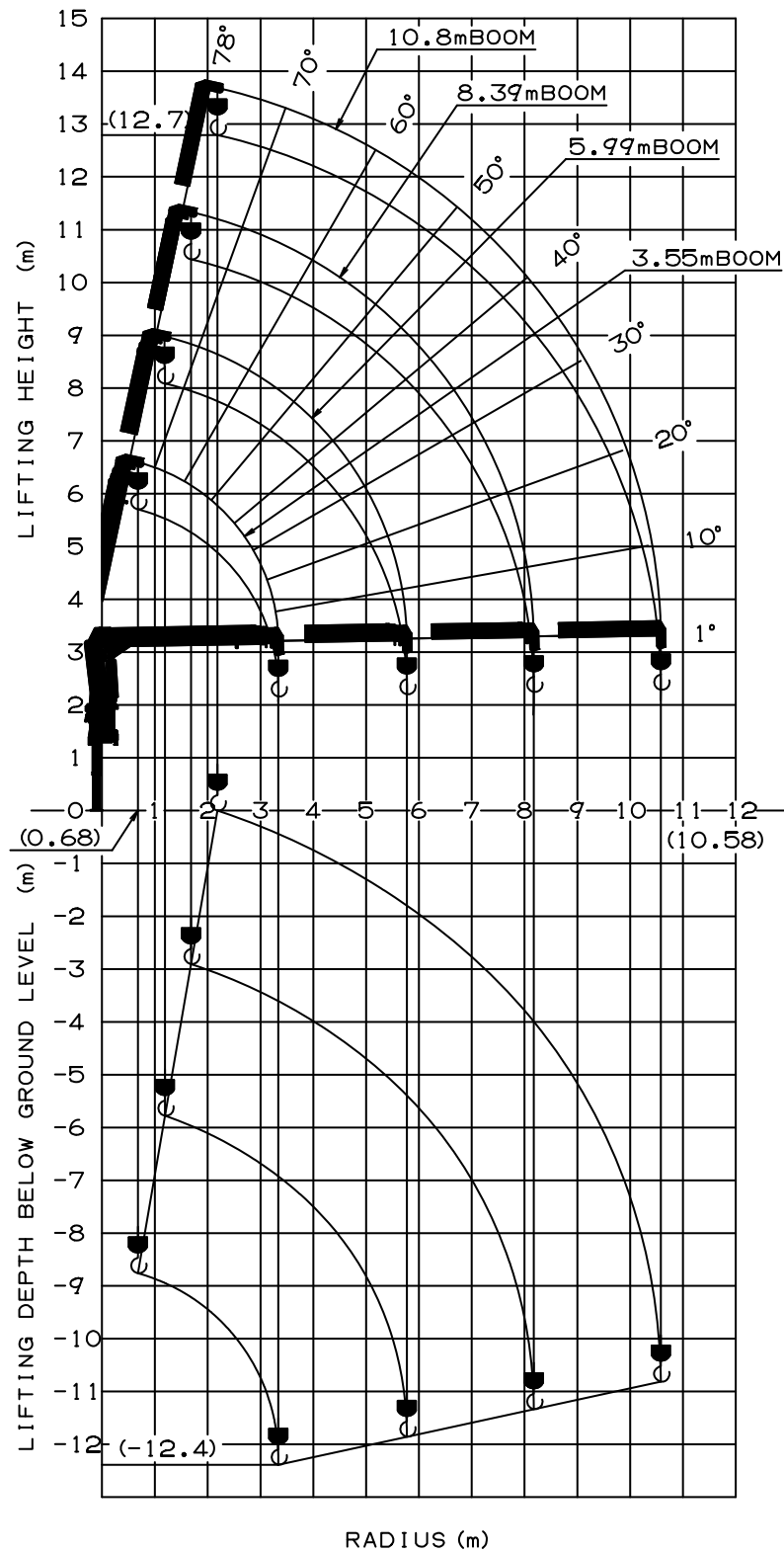

NOTE: The above lifting heights and boom angles are based on a straight (unladen) boom, and allowance should be made for boom deflection obtained under laden conditions.

DIMENSIONS

[TM-ZE554HS]

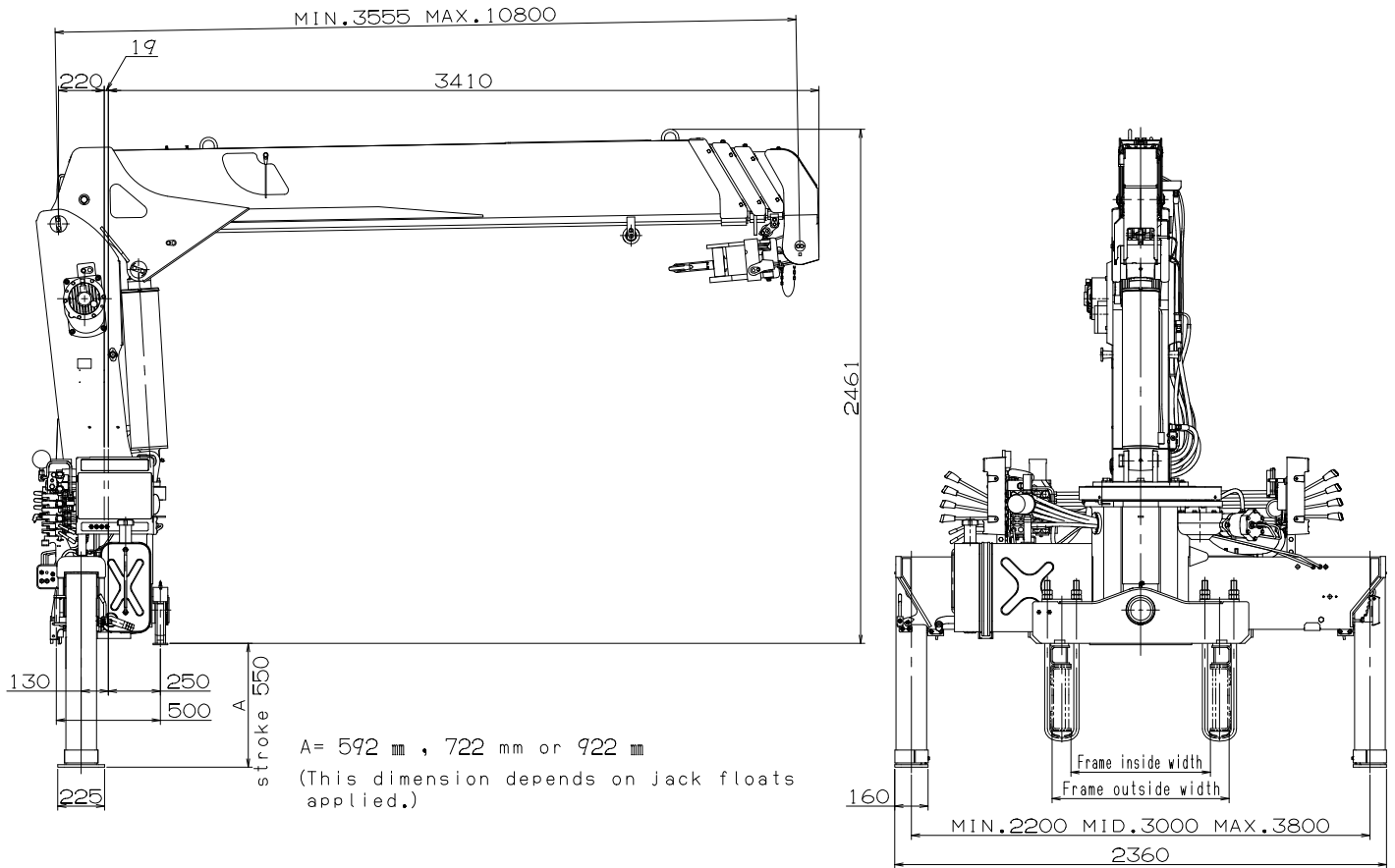

GENERAL DATA FOR SUITABLE TRUCKS

- Gross vehicle mass (including crane mass) ----- 15,000 to 25,000 kg
 - P.T.O. torque ----- 157 N-m{16 kgf-m} min.
 - P.T.O. revolution ----- Approx. 270 to 2,800 min⁻¹{rpm}
 - Width for crane mounting ----- Approx. 750 mm min.
 - Frame ----- Weight distribution and frame strength should be calculated for each truck
 - Frame width range (inside to outside) ----- Approx. 610 to 960 mm
 - Frame height (ground to frame top) ----- Approx. 1,235 mm max.
- (Height of crane mounting base can be changed by combination of jack floats and crane bases)