

TADANO CARGO CRANE

MODEL : **TM-ZE555HS**

CRANE SPECIFICATIONS

<u>CRANE CAPACITY</u>	5,000 kg at 2.5 m (5-part line)
<u>BOOM</u>	Five-sectioned, fully powered partly synchronized telescoping boom of heptagonal box construction Retracted length -----3.77 m Extended length -----13.34 m Extending speed ----- 9.57 m / 25 s Elevation ----- Elevated by a double-acting hydraulic cylinder Elevating speed ----- 1° to 78° / 12 s Boom point ----- 3 sheaves
<u>WINCH</u>	Hydraulic motor driven Spur gear speed reduction, provided with mechanical brake and cable follower Single line pull ----- 9.90 kN {1,010 kgf} Single line speed ----- 66 m/min (at 4th layer) Wire rope Diameter x length --- 8 mm x 97 m Breaking strength --- 50.1 kN {5.1 tf} Construction ----- 7 x 7 + 6 x WS(26) Hook block ----- 2 sheaves
<u>HOOK STOWING DEVICE</u>	Mechanically stowed beneath boom top portion

Specifications are subject to change without notice.

SLEWING

Hydraulic motor driven Worm gear speed reduction
 Continuous 360° full circle slewing on ball bearing slew ring
 Automatic slewing lock
 Slewing speed ----- 2.5 min⁻¹ {rpm}

OUTRIGGERS

Manually extended sliders and hydraulically extended jacks
 Integral with crane frame Power up and down
 Extended width ----- Min. 2,200 mm
 Mid. 3,000 mm
 Max.3,800 mm

HYDRAULICS

Hydraulic pump ----- Single gear pump
 Hydraulic motors ----- Axial piston type for winch
 Axial piston type for slewing
 Control valves ----- Multiple control valves with integral
 safety valve
 Oil tank capacity ----- approx. 48 L

SAFETY DEVICES

AML(Automatic Moment Limiter)
 Load indication
 Load moment ratio to rated load indication
 Warning alarm
 Over load limiter
 WHL(Working Height Limiter)
 Load indicator
 Over-unwinding prevention
 Terminal for emergency stop switch
 Over-winding alarm
 Anti-two-block device
 Hook safety latch
 Hydraulic safety valves, check valves and holding valves
 Level gauge

CRANE MASS

Approx. 2,040 kg (includes standardized mounting parts)

NOTE : Operating speeds of the crane are guaranteed under the condition that the pump delivery is 60 L/min.

RATED LIFTING CAPACITIES IN KILOGRAMS
Crane Strength Rated Capacities

Load Radius	3.77m Boom	Load Radius	6.21 m Boom	Load Radius	8.59 m Boom	Load Radius	10.97 m Boom	Load Radius	13.34 m Boom
2.5 m and below	5,000	2.5 m and below	4,000	2.5 m and below	3,080	4.0 m and below	2,180	5.0 m and below	1,380
2.8 m	4,000	2.8 m	4,000	3.0 m	3,080	4.5 m	2,130	6.0 m	1,280
3.55m	3,100	3.6 m	3,080	3.6 m	3,080	5.0 m	1,980	7.0 m	1,180
		3.9 m	2,880	3.9 m	2,880	6.0 m	1,680	8.0 m	1,030
		4.5 m	2,480	4.5 m	2,480	7.0 m	1,380	9.0 m	930
		5.0 m	2,180	5.0 m	2,180	8.0 m	1,180	10.0 m	830
		5.5 m	1,930	5.5 m	1,930	9.0 m	1,030	11.0 m	750
		5.99m	1,730	6.0 m	1,730	10.0 m	930	12.0 m	680
				6.5 m	1,580	10.75m	850	13.12m	600
				7.0 m	1,430				
				7.5 m	1,330				
				8.37m	1,130				

- NOTES : 1. Capacities in these tables include slings and similarly used load lifting devices, and they must be added to the mass of the load. They don't, however, include the mass of hook block (45kg).
2. The above numerical values of total rated loads are based on crane strength only. The total rated loads based on stability may lower than those in the above table depending on the loading conditions and the types of the chassis.

Empty Chassis Rated Capacities

Table A

Load Radius	3.77 m Boom		Load Radius	6.21 m Boom		Load Radius	8.59 m Boom		Load Radius	10.97 m Boom	Load Radius	13.34 m Boom
	Extension width of outriggers			Extension width of outriggers			Extension width of outriggers			Extension width of outriggers		Extension width of outriggers
	Maximum	Minimum		Maximum	Minimum		Maximum	Minimum		Maximum		Maximum
2.5 m and below	5,000	2,380	2.6 m and below	4,000	2,380	2.6 m and below	3,080	2,380	4.0 m and below	2,180	5.0 m and below	1,380
2.8 m	4,000	2,080	2.8 m	4,000	2,080	3.4 m	3,080	1,480	4.5 m	1,880	6.0 m	1,080
3.55m	2,900	1,330	3.6 m	2,880	1,330	3.6 m	2,880	1,330	5.0 m	1,530	7.0 m	850
			3.9 m	2,480	1,130	3.9 m	2,480	1,130	6.0 m	1,080	8.0 m	650
			4.5 m	1,880	880	4.5 m	1,880	880	7.0 m	850	9.0 m	500
			5.0 m	1,580	680	5.0 m	1,580	680	8.0 m	650	10.0m	450
			5.5 m	1,330	580	5.5 m	1,330	580	9.0 m	500	11.0m	380
			5.99m	1,080	450	6.0 m	1,080	450	10.0m	450	12.0m	350
						6.5 m	1,000	430	10.75m	400	13.12m	300
						7.0 m	880	350				
						7.5 m	780	300				
						8.37m	600	200				

Table B

Load Radius	3.77m Boom		Load Radius	6.21 m Boom		Load Radius	8.59 m Boom		Load Radius	10.97 m Boom	Load Radius	13.34 m Boom
	Extension width of outriggers			Extension width of outriggers			Extension width of outriggers			Extension width of outriggers		Extension width of outriggers
	Maximum	Minimum		Maximum	Minimum		Maximum	Minimum		Maximum		Maximum
2.5 m and below	5,000	3,080	2.5 m and below	4,000	3,080	2.5 m and below	3,080	3,080	4.0 m and below	2,180	5.0 m and below	1,380
2.8 m	4,000	2,480	2.8 m	4,000	2,480	3.0 m	3,080	2,230	4.5 m	2,130	6.0 m	1,280
3.55m	3,100	1,630	3.6 m	3,080	1,630	3.6 m	3,080	1,630	5.0 m	1,880	7.0 m	1,080
			3.9 m	2,880	1,380	3.9 m	2,880	1,380	6.0 m	1,380	8.0 m	830
			4.5 m	2,380	1,080	4.5 m	2,380	1,080	7.0 m	1,080	9.0 m	680
			5.0 m	1,930	880	5.0 m	1,930	880	8.0 m	830	10.0m	600
			5.5 m	1,630	730	5.5 m	1,630	730	9.0 m	680	11.0m	500
			5.99m	1,380	600	6.0 m	1,380	600	10.0m	600	12.0m	450
						6.5 m	1,230	580	10.75m	530	13.12m	380
						7.0 m	1,080	480				
						7.5 m	980	430				
						8.37m	780	300				

Table C

Load Radius	3.77m Boom		Load Radius	6.21 m Boom		Load Radius	8.59 m Boom		Load Radius	10.97 m Boom	Load Radius	13.34 m Boom
	Extension width of outriggers			Extension width of outriggers			Extension width of outriggers			Extension width of outriggers		Extension width of outriggers
	Maximum	Minimum		Maximum	Minimum		Maximum	Minimum		Maximum		Maximum
2.5 m and below	5,000	3,080	2.5 m and below	4,000	3,080	2.5 m and below	3,080	3,080	4.0 m and below	2,180	5.0 m and below	1,380
2.8 m	4,000	2,680	2.8 m	4,000	2,680	3.0 m	3,080	2,530	4.5 m	2,130	6.0 m	1,280
3.55m	3,100	1,830	3.6 m	3,080	1,830	3.6 m	3,080	1,830	5.0 m	1,980	7.0 m	1,180
			3.9 m	2,880	1,580	3.9 m	2,880	1,580	6.0 m	1,680	8.0 m	1,030
			4.5 m	2,480	1,280	4.5 m	2,480	1,280	7.0 m	1,350	9.0 m	900
			5.0 m	2,180	1,030	5.0 m	2,180	1,030	8.0 m	1,050	10.0m	750
			5.5 m	1,930	880	5.5 m	1,930	880	9.0 m	900	11.0m	650
			5.99m	1,680	730	6.0 m	1,680	730	10.0m	750	12.0m	580
						6.5 m	1,530	650	10.75m	680	13.12m	480
						7.0 m	1,380	580				
						7.5 m	1,200	500				
						8.37m	1,000	380				

Table D

Load Radius	3.77 m Boom		Load Radius	6.21 m Boom		Load Radius	8.59 m Boom		Load Radius	10.97 m Boom	Load Radius	13.34 m Boom
	Extension width of outriggers			Extension width of outriggers			Extension width of outriggers			Extension width of outriggers		Extension width of outriggers
	Maximum	Minimum		Maximum	Minimum		Maximum	Minimum		Maximum		Maximum
2.5 m and below	5,000	3,330	2.5 m and below	4,000	3,330	2.5 m and below	3,080	3,080	4.0 m and below	2,180	5.0 m and below	1,380
2.8 m	4,000	2,680	2.8 m	4,000	2,680	3.0 m	3,080	2,530	4.5 m	2,130	6.0 m	1,280
3.55m	3,100	1,830	3.6 m	3,080	1,830	3.6 m	3,080	1,830	5.0 m	1,980	7.0 m	1,180
			3.9 m	2,880	1,580	3.9 m	2,880	1,580	6.0 m	1,680	8.0 m	1,030
			4.5 m	2,480	1,280	4.5 m	2,480	1,280	7.0 m	1,380	9.0 m	930
			5.0 m	2,180	1,030	5.0 m	2,180	1,030	8.0 m	1,180	10.0m	830
			5.5 m	1,930	880	5.5 m	1,930	880	9.0 m	1,030	11.0m	750
			5.99 m	1,730	730	6.0 m	1,730	730	10.0m	930	12.0m	680
						6.5 m	1,580	650	10.75m	850	13.12m	600
						7.0 m	1,430	580				
						7.5 m	1,330	500				
						8.37m	1,130	380				

- NOTES : 1. Empty Chassis Rated Capacities in these tables depend on condition that crane is set level on firm level ground.
2. Capacities in these tables include slings and similarly used load lifting devices, and they must be added to the mass of the load. They don't , however, include the mass of hook block (45kg).
3. For boom lengths not shown, use the rated lifting capacity of next longer boom.
4. When outriggers are extended to middle extension width, use the rated lifting capacities for outriggers are extended to minimum extension width.
5. For boom lengths longer than 8.59m, extend outriggers to maximum.
6. 10.97m boom means \sphericalangle mark on 4th boom section side plate is half seen.
7. Empty Chassis Rated Capacities table A, B, C and D depend on the types of chassis.
8. Empty Chassis Rated Capacities are shown for over - side areas and over - rear area. These capacities for over - front area may lowered depending on the types of chassis.

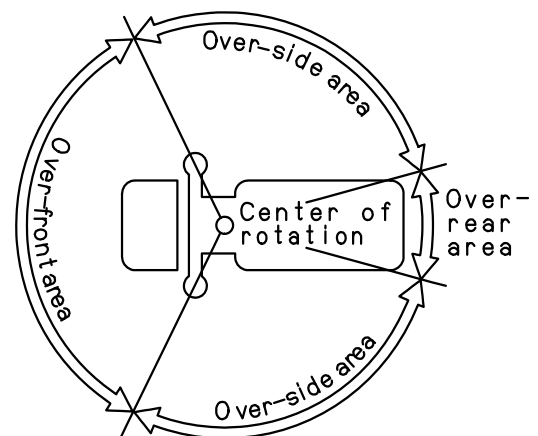
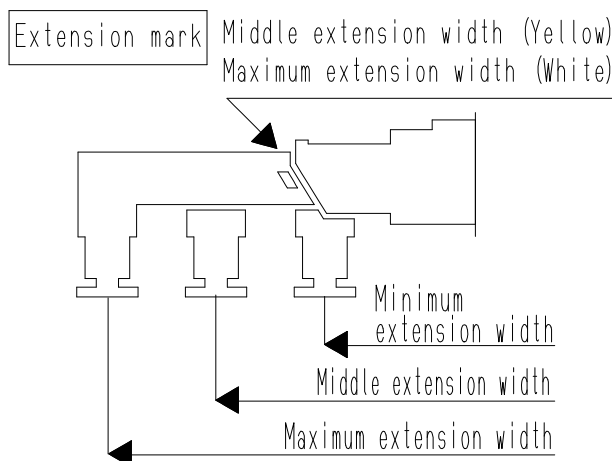

WORKING RANGE

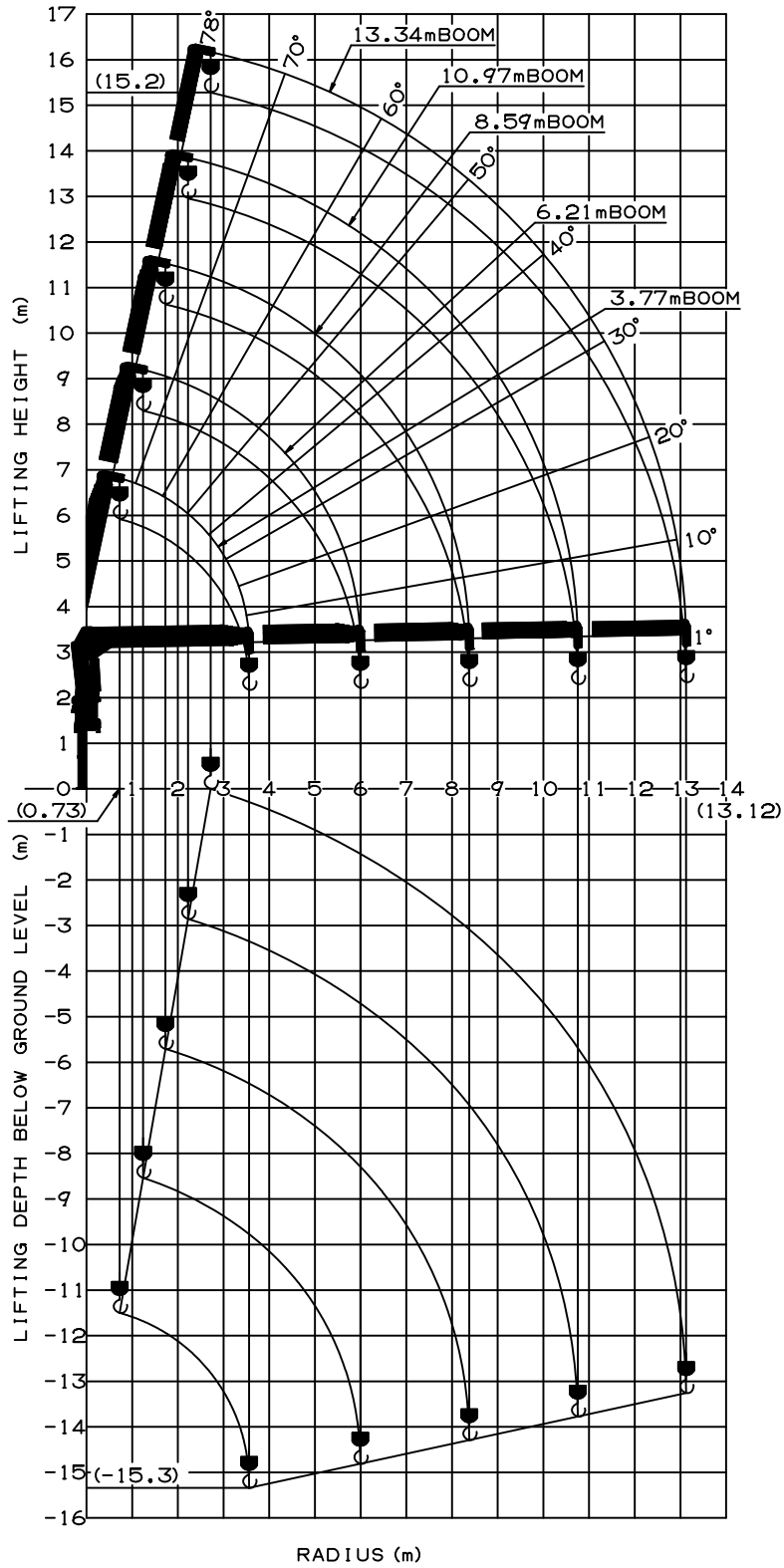

NOTE: The above lifting heights and boom angles are based on a straight (unladen) boom, and allowance should be made for boom deflection obtained under laden conditions.

DIMENSIONS [TM-ZE555HS]

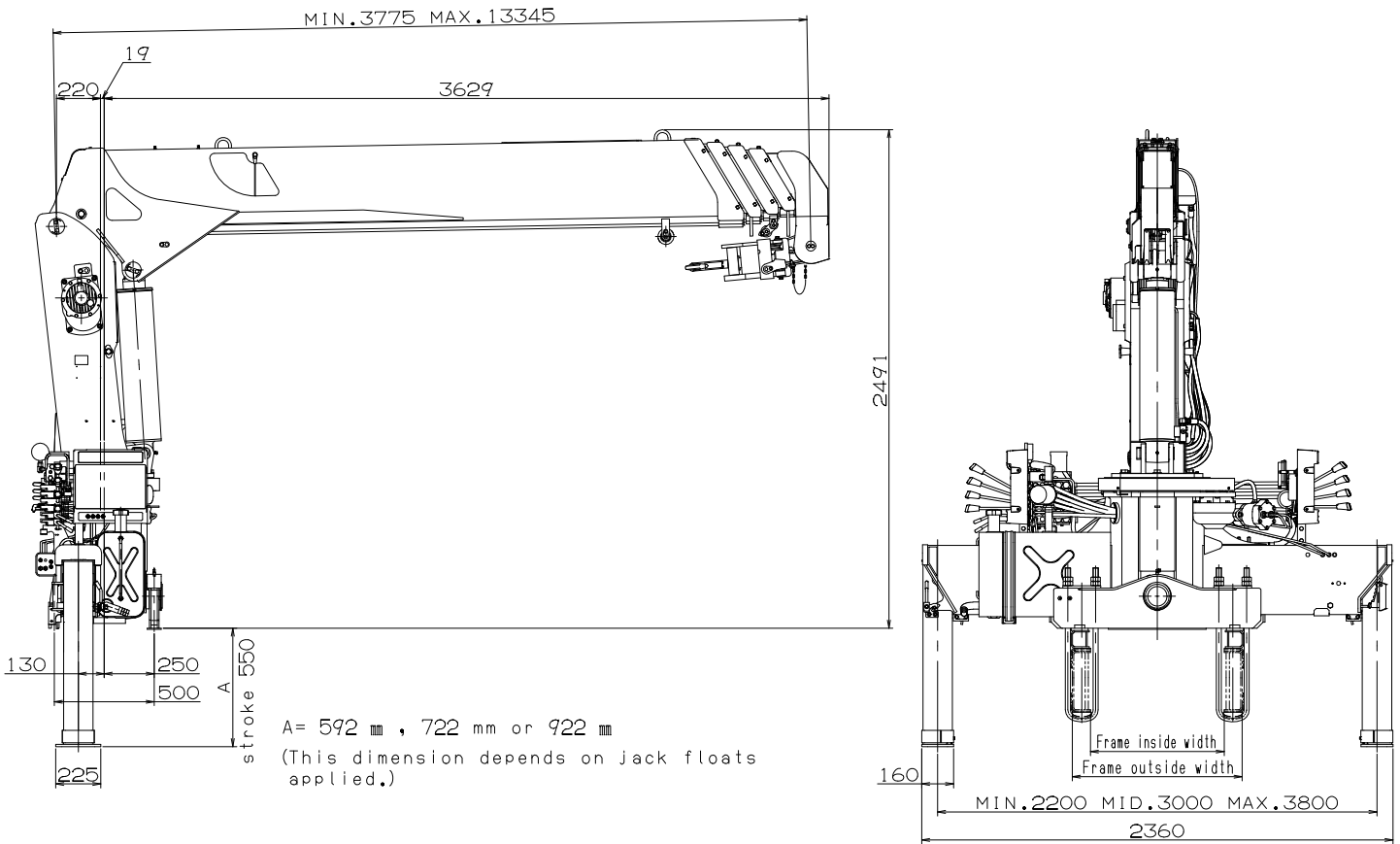

GENERAL DATA FOR SUITABLE TRUCKS

- Gross vehicle mass (including crane mass) ----- 15,000 to 25,000 kg
- P.T.O. torque ----- 157 N-m{16 kgf-m} min.
- P.T.O. revolution ----- Approx. 270 to 2,800 min⁻¹{rpm}
- Width for crane mounting ----- Approx. 750 mm min.
- Frame ----- Weight distribution and frame strength
should be calculated for each truck
- Frame width range (inside to outside) ----- Approx. 610 to 960 mm
- Frame height (ground to frame top) ----- Approx. 1,235 mm max.
(Height of crane mounting base can be changed
by combination of jack floats and crane bases)